

Assuring Delivery of Power for Critical Applications



Application of a New Monitor and Control System

AiNET®
11710 Montgomery Road
Beltsville, MD 20705 USA
www.ai.net

Abstract

Assuring Delivery of Power for Critical Applications

Application of a New Monitor and Control System

Demands are rising for 100% availability of critical power in diverse environments such as Internet data centers, hospitals, public safety facilities, etc. Yet until the introduction of AiNET's patented Critical Power Protection Supervisor, all such environments were subject to critical power outages stemming from particular forms of:

- Power transients.
- Lightning strikes.
- Loss of phase(s) in main power.
- Loss of synchronization between phases in main power.
- Voltage drops in one or more phases of main power.
- Loss or diminution of energy storage capabilities in the critical power delivery chain.
- Threshold offsets between elements in the critical power delivery chain, most typically between the Automatic Transfer Switch and the Uninterruptible Power Supply.
- Loss or diminution of Uninterruptible Power Supply functionality.

The underlying shortcoming in critical power delivery has been the lack of systems-level operational coordination between critical power's four key elements: a Secondary Power Source (usually a Generator), an Automatic Transfer Switch, an Uninterruptible Power Supply, and an Energy Storage Element (usually Battery Sets). The Critical Power Protection Supervisor provides a management overlay that unifies the discrete critical power elements into an effective, critical power delivery system.

Thresholds based on stored energy in the system are defined. These system thresholds are monitored by the Critical Power Protection Supervisor (CPPS) and if system stored energy falls beneath one of them, the CPPS issues commands to engage the Generator (Secondary Power Source). Thus, preemptive action is taken if the system has fallen into a state of *exposure to the potential* of a critical power outage. Notification of this action to the system operators will allow them to diagnose the situation in a workable timeframe and not in the midst of an outage condition.

In different applications, the Critical Power Protection Supervisor is ideally suited to manage power systems drawing on both traditional and renewable power sources, as well as managing energy costs through peak shaving, the process of moving on or off the grid according to short-term energy prices.

The approach of constant systems-level monitoring and preemptive action to critical power management taken by the Critical Power Protection Supervisor virtually eliminates outages in well-designed critical power environments.

AiNET's operations reflect its deep understanding of critical infrastructure's environment and the businesses and applications relying upon it. Emblematic of its appreciation for reliability, AiNET owns and operates one of the world's few, certified, TIA-942 Tier IV data centers, the site of the first field deployment of the Critical Power Protection Supervisor. More information can be found at www.ai.net.

Assuring Delivery of Power for Critical Applications

Application of a New Monitor and Control System

Demands for power certainty - 100% power availability – continue to increase. 100% uptime is an essential operational requirement in diverse sectors including medical care, public safety, transportation systems, financial systems, finely controlled manufacturing process, and the Internet “Cloud”.

In an effort to minimize power unavailability for the application (the Load, e.g. an Internet data center), several elements are commonly deployed to supplement or substitute for (typically utility-provided) Main Power should it be unavailable. In most industrial/commercial applications, the backup has the elements and general schema shown in Figure 1, where we note the introduction of four key elements: a Secondary Power Source, a (Automatic) Transfer Switch, an Uninterruptible Power Supply (UPS), and an Energy Storage Element.

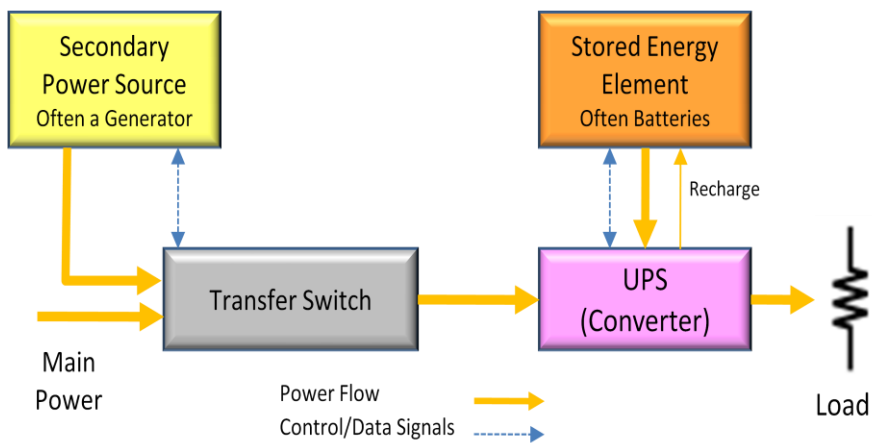

Figure 1. Typical Power Delivery Elements in a Critical Power Application

As noted in the figure, without loss of generality we will describe the Secondary Power Source as a Generator and the Energy Storage Element as a Battery Set.

As its name suggests, the (Automatic) Transfer Switch (TX) provides the means to direct either Main or Secondary Power to the Load. The sophisticated UPS stands ready to draw energy rapidly from the batteries to augment or fully substitute power for the source(s) for short time periods. In a common application, the UPS also provides a conduit to restore energy to the batteries.

The elements of Figure 1 are employed for the sole purpose of delivering power to the Load without fail, i.e. on a 100% uptime basis. While there is a measure of communications and control between some of the elements, collectively they are not unified on a system basis. As such, today’s elemental approach several remains susceptible to outages from several conditions, some of which are commonly-occurring.

Addressing this shortcoming, the patented (U.S. Patent 7,962,772), AiNET Critical Power Protection Supervisor (CPPS) was developed to unify the distinct power delivery elements into a critical power *system*. By continually monitoring the state of the elements and directing preemptive action if a condition that could result in an outage develops, the CPPS virtually eliminates outages in critical power environments.

Failure Modes

To help explain the role of the Critical Power Protection Supervisor, it is useful to understand failure modes in the current approach.

Figure 2.1 represents the timeline of a hard failure of the Main Power, and the Elements' response to it at the time of failure and through Main Power restoration. Looking at the figure and the Key, we note that at the moment of failure, t_{MF} , the UPS detects the failure and immediately draws energy from the batteries to provide power (the red bar) to the Load.

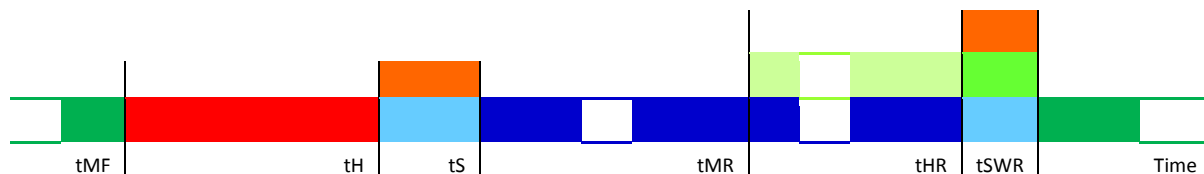
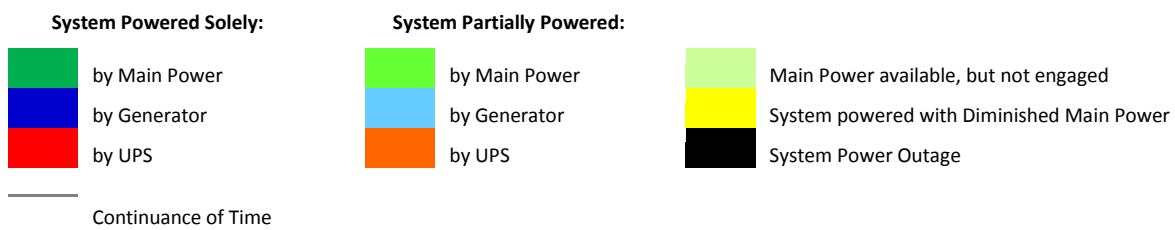

Figure 2.1. Timeline of Hard Failure and Restoration of Main Power in a Critical Power Environment.

Key for Figure 2.1



tMF	Time of detection of failure in Main Power
tH	Transfer Switch's designated hold time; time between failure detection and engagement of Generator
tS	Stabilization time of Generator
tMR	Time of detection of return of Main Power
tHR	Transfer Switch's designated hold time on restoral; time between detection of return and perceived stabilization of Main Power
tSWR	Switchover time from Generator to Main Power on restoral
tSF	Time of Soft Failure in Main Power Undetected by Transfer Switch (not shown in Figure 2.1.)

In this example the Transfer Switch (TX) also detects the loss of Main Power at time t_{MF} . To avoid the strain placed on the Generator by short on/off cycles, the TX waits a (programmable) hold time, t_H , for the outage in Main Power to extend before signaling the Generator to start. Generally there is some Generator stabilization interval, t_S , during which the UPS continues to supply or supplement power to the Load. Once the Generator has stabilized and can power the Load properly, the UPS stands down and the battery drain halts.

The first solid blue interval in the figure represents the time during which the Main Power is not available and all power is provided by the Generator. At time t_{MR} , the TX detects the return of Main Power. However, to ensure that the Main Power is stable (not intermittent), the TX waits a prescribed

period of stable power time, t_{HR} , before re-switching the power source to Main Power. Often there would be a brief outage at switchover, but a brief re-engagement by the UPS bridges the gap.

In this example of a hard failure of Main Power and its return and reinstition, all the elements engaged as planned, and the Load did not suffer an outage.

Once Generator or Main Power is in place, the UPS will begin recharging the batteries. Note that the battery recharge cycle (note shown) is very long compared to the discharge cycle. Battery plants are sized for the Load and often can power the Load for less than 3 minutes.

The time interval ($t_H + t_S$) is the period during which the UPS draws energy from the batteries to power the Load before the Generator assumes this duty. Therefore, any time the batteries' deliverable energy is less than can power the Load for interval ($t_H + t_S$), the Load *is at risk* of suffering an outage if the Main Power fails. We will call this energy level E_1 and designate the associated time interval ($t_H + t_S$) as T_1 .

Figure 2.2a depicts the situation in which the Main Power experiences several brief outages, none of which is of duration greater than t_H . Such a pattern might be seen during thunderstorms. Due to the brevity of each outage, the Generator is not engaged. Drawing energy from the batteries, the UPS supplements power for the gaps in Main Power.



Figure 2.2a. A Series of Brief Outages in Main Power Diminish Energy Stored in the Batteries.

Figure 2.2b depicts the power outage (black bar) experienced by the Load that occurs when a series of brief outages ultimately exhausts the batteries. In this figure, Main Power is shown as returning, but note that until the batteries recharge sufficiently, another loss of Main Power would result in another full outage to the Load. If the outage exceeds duration t_H , the Generator will engage.



Figure 2.2b. A Series of Brief Outages in Main Power Exhaust the Batteries and an Outage Occurs.

The outage presented in Figure 2.2b is representative of a type of outage condition that plagues all critical power environments. In such conditions, although the UPS becomes active to the point of exhausting the batteries, no command is issued for the Generator to engage.

This type of outage condition is often caused by particular forms or patterns of:

- Power transients.
- Lightning strikes.
- Loss of phase(s) in main power.

- Loss of synchronization between phases in main power.
- Voltage drops in one or more phases of main power.

In all of these cases, the batteries can exhaust and an outage can occur, without Generator engagement.

Figure 2.3 depicts another of these subtle outage mechanisms. In such an instance, the deficiency in Main Power is undetected by the TX. For example, not all TXs in operation today can detect loss or diminution of a phase (in 3-phase power delivery). In the example, the more sophisticated UPS does detect the problem and supplements the power until battery energy is exhausted. At this point, the Load experiences an outage that will persist until the Generator is engaged.



Figure 3. An Undetected Shortcoming in Main Power Leads to a Power Outage.

The above figures represent situations where, despite best efforts to the contrary, critical outages can - and do - occur. AiNET, which operates data centers that are home to a portion of Internet “Cloud”, recognized the shortcomings of the current approach, and developed the Critical Power Protection Supervisor to address the situation.

The Critical Power Protection Supervisor

Depicted schematically in Figure 3, the AiNET CPPS is a management overlay system for the elements of the critical power chain. As such it can interact with the Secondary Power Source (the Generator in the

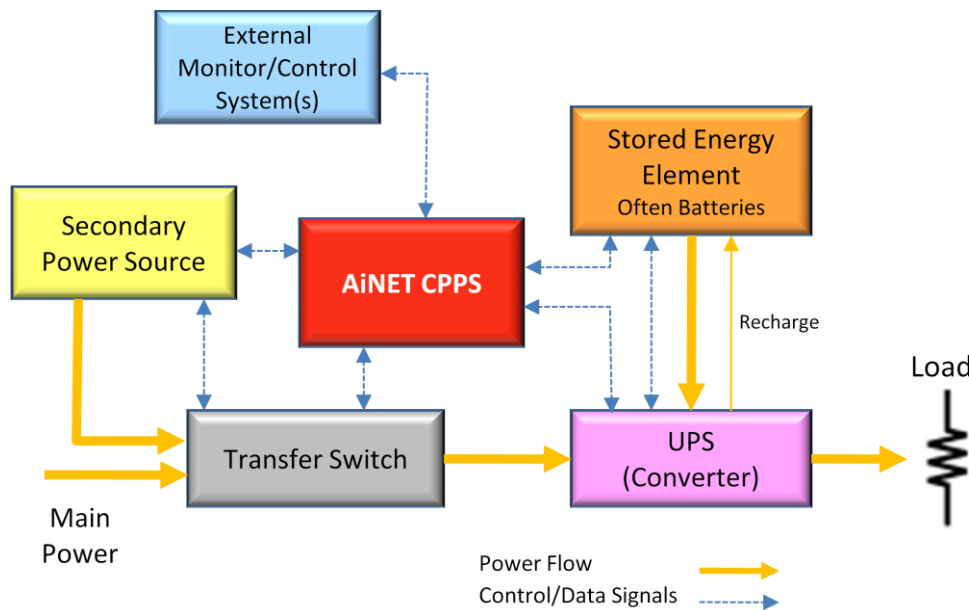

Figure 3. AiNET Critical Power Protection Supervisor Interfaces with All Power Delivery Elements to Unify Them in a System.

above examples), the Transfer Switch, the UPS, and the Energy Storage Element (batteries in the above). The CPPS fills in the gaps in the set of power delivery elements to create a power assurance system to drive the Load continually.

Previously, E1 was defined as the amount of stored energy required to power the Load for duration T1, the time interval ($t_H + t_S$). In practice, some cushion is added to E1 so T1 is marginally longer than ($t_H + t_S$). It follows that E1 is a critical threshold in the system: any time stored energy is below E1, loss of the Main Power for a duration greater than t_H will result in an outage at the Load. Stated another way, if stored energy falls below E1, the system must operate on Secondary Power to avoid the *risk* of suffering an outage at the Load. Note that E1 is primarily a function of t_H and the size of the Load.

Similarly, we can define E2 as the amount of stored energy to power the Load for time period T2, the interval ($t_H + t_S + t_{SWR}$). With margin, E2 is the energy level corresponding to the point at which utility power can be used to recharge the Energy Storage Element toward its full capacity.

Therefore, an essential duty of the CPPS is to monitor stored energy and, if it falls below E2, order the system to engage Secondary Power (if not already engaged). *This order is given regardless of whether Main Power is available and in service because the loss of Main Power at this point would result in an outage.* Also, the systems' operators are notified of the condition so they can analyze the situation and take action as necessary without having to operate in the crisis environment of an outage at the Load.



Figure 4. Outcomes of Undetected Failure Condition without (upper) and with (lower) Critical Power Protection Supervisor.

Figure 4 depicts the action of the CPPS in preventing an outage. The upper portion of the figure shows the corresponding stored energy levels of the outage depicted in Figure 2.3. In the lower portion, we note that once the E2 threshold is reached, the CPPS intervenes and Secondary Power is engaged. The system operators are notified of the event and can take appropriate action.

Another failure mechanism stems from the loss or diminution of system energy storage capabilities (e.g. failing, aging batteries or flywheel seizure in flywheel energy storage). In such a case, once the E2 threshold is breached, the CPPS would have engaged the Generator regardless of the current state of operations.

Therefore, by continually monitoring the state of the power delivery elements, and taking action to avoid the potential of failure, the Critical Power Protection Supervisor virtually eliminates outages in critical power environments.

There are at least two other failure conditions to note. One stems from offsets in thresholds between elements in the critical power delivery chain, most typically between the TX and the UPS. For example the TX may consider a voltage level of 271V on a phase acceptable, while the UPS condition power to a 277V level. In doing so over time, the UPS gradually exhausts the batteries. Once again, the CPPS takes action when the E2 threshold is crossed. Another failure condition is when the UPS itself fails. Any failure in the UPS (often manifested by the UPS operating in a power pass-through mode) is automatic grounds for the CPPS to command action; in this case, most likely directing the whole power chain to switch to a backup chain.

Other Considerations and Applications

As a unified, critical power manager, the Critical Power Protection Supervisor can interface directly with the power elements and other monitoring systems, store measurable parameters, and direct action as needed. A cost benefit of the CPPS is that its additional level of monitoring can be used to offset equipment upgrades or make a trade-off between the potential of more Generator time and battery upgrades.

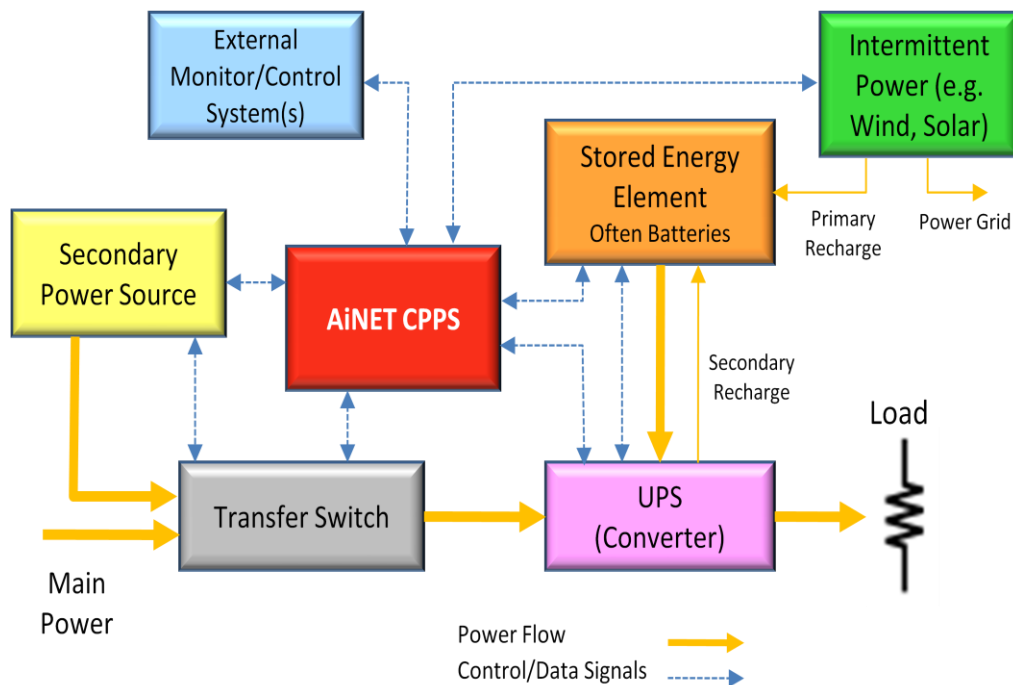

Figure 5. Integration of Power Derived from Renewable, but Potentially Intermittent, Sources.

In a related application, with continued decreases in the cost of generating power from renewable resources, these resources can and will be integrated into critical power delivery systems. Figure 5 depicts one such integration. As shown, the intermittency of power from renewable resources is anticipated. As such, two sources recharge the Energy Storage.

Figure 6 considers a situation, perhaps for a residential market, in which renewable power is designated as the primary power source and, turning the tables, utility power serves as Secondary Power. All of the

principles discussed above apply, although the scale of equipment changes as might certain parameters. For example, tH might be set at a very low value since no generator is being exercised and there would be stronger incentives to restrict the number and cost of batteries.

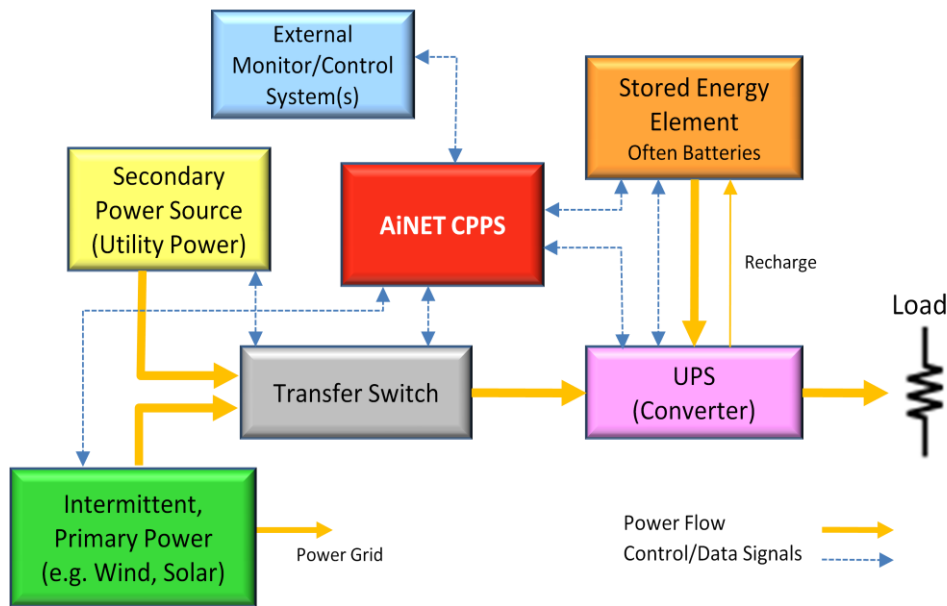

Figure 6. Application of the AiNET Critical Power Protection Supervisor Where an Intermittent Source Is Designated as the Primary Power Source.

The Critical Power Protection Supervisor can be applied to take advantage of peak shaving to control energy costs. Peak shaving is the process by which utilities can restrict supply (with accompanying financial incentives) to participating customers during peak periods of consumption, such as very hot days. For example, in the residential market it is not uncommon to see utility-managed on/off controls placed on air conditioning units of participating customers (for cash credits).

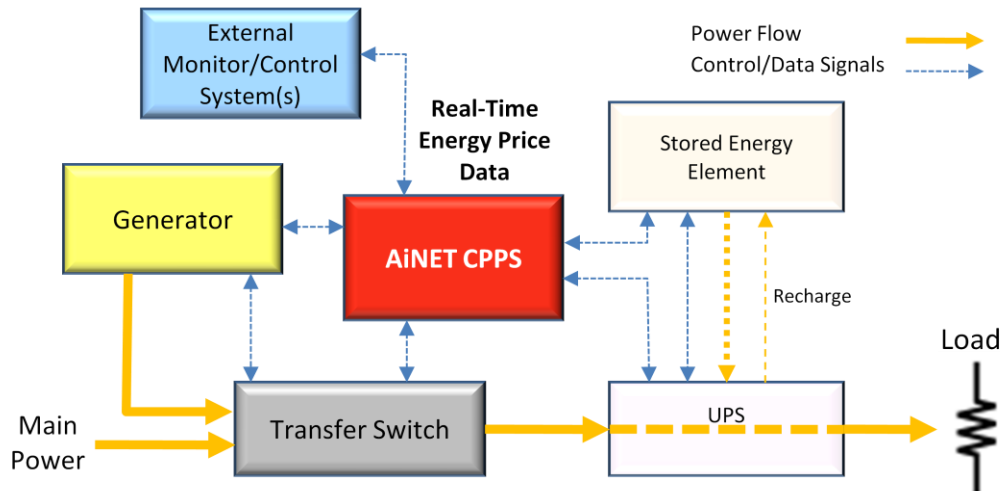

Figure 7. Application of the AiNET Critical Power Protection Supervisor in Energy Cost Control through Real-Time Management of Peak Shaving.

Large energy consumers in commercial and industrial settings have more means available to them to participate in peak shaving – particularly if they have a generator available as a secondary power source. Figure 7 depicts the application of the Critical Power Protection Supervisor to save costs through peak shaving. In the figure, the Energy Storage Element and UPS have been deemphasized without loss of generality because this CPPS application could also occur in non-critical power environments that do not have these elements (such as certain factories).

In energy markets the cost of energy can skyrocket during the very highest demand hours, which is why incentives to cut demand at these times can come into play. As depicted in Figure 7, the CPPS is receiving a real-time feed of prices on energy markets. Taking this data and working with parameters established between the operator and his energy supplier(s), the CPPS will engage and disengage the Generator accordingly. Therefore, at times of highest energy costs, the operator has removed his facility from the power grid (Main Power) and in return receives compensation from his energy supplier.

While the preceding use is not necessarily in a critical power environment, it does demonstrate the wide-ranging application of the Critical Power Protection Supervisor.

* * * * *

Demands for power certainty, a 100% uptime basis, are increasing, as are demands for power system management in new locations and applications. While today’s approaches have merit, that power outages occur in locations where power is viewed as “highly redundant” demonstrates that there are gaps in today’s approaches.

The approach of constant systems-level monitoring and preemptive action to critical power management taken by the patented AiNET Critical Power Protection Supervisor virtually eliminates outages in critical power environments, ushering in a new era in power availability.

AiNET® Group companies develop and sustain critical infrastructure that underpins the Internet and everything it touches. AiNET companies are recognized leaders in the design, construction, operation, and support of Internet data centers, optical fiber networks, and critical applications.

AiNET’s operations reflect its deep understanding of critical infrastructure’s environment and the businesses and applications relying upon it. Emblematic of its appreciation for reliability, AiNET owns and operates one of the world’s few, certified, TIA-942 Tier IV data centers, the site of the first field deployment of the Critical Power Protection Supervisor. More information can be found at www.ai.net.